

Oasi

Divani componibili | *Modular seating systems*

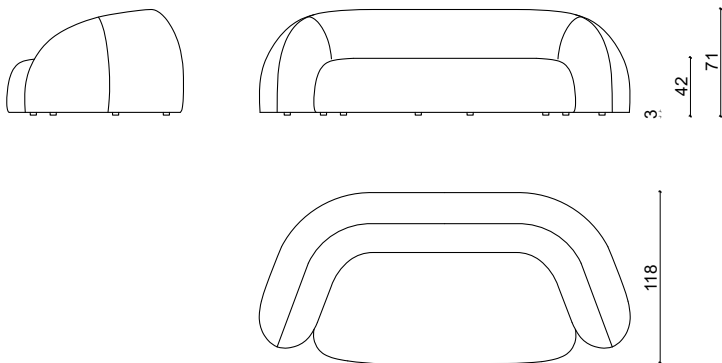

Rivestimenti: Tessuto - Cuciture tono su tono.

Struttura: Telaio composto da multistrato, legno e derivati (classe E1).
Molleggio con cinghie elastiche ad alta resistenza.

Seduta: Poliuretano espanso ad alta portanza e densità variabile rivestito in fibra poliestere.

Schienale: Poliuretano espanso sagomato a densità differenziate rivestito in fibra poliestere.

Piedi: Legno.

Upholstery: Fabric - Tone on tone stitching.

Structure: Plywood, wood and derivatives (class E1). Suspension with high resistance elastic belts.

Seat: Polyurethane foam with high support and variable density covered with polyester fibre.

Backrest: Moulded polyurethane foam with variable densities covered with sterilized feather and polyester fibre.

Feet: Wood.

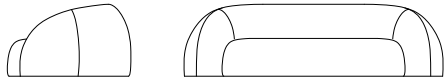

350

L 248 x P 118 x H 71 cm

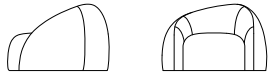
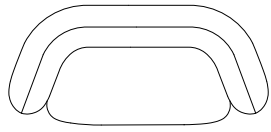

110 - 100

L 100 x P 98 x H 65 cm

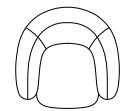
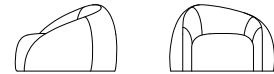
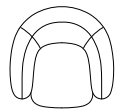

L

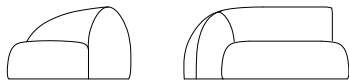

230 - 220

L 160 x P 118 x H 71 cm

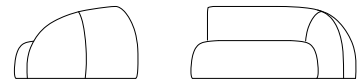
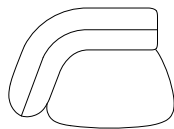

R

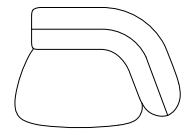

L



170 - 180

L 140 x P 118 x H 71 cm



R



L



150 - 160

L 144 x P 118 x H 71 cm

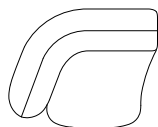

R

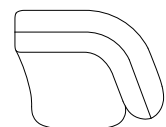

L

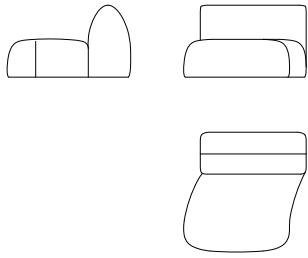

130 - 120
L 119 x P 118 x H 71 cm

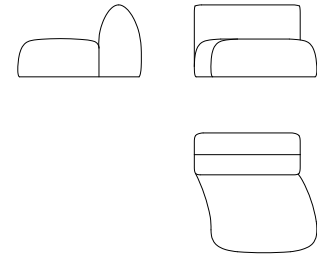

R

L

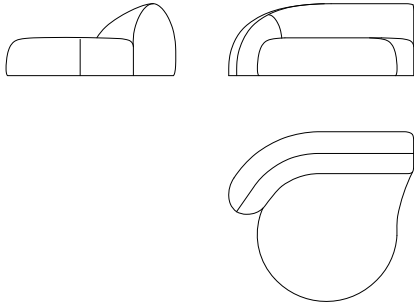

570 - 560
L 174 x P 162 x H 71 cm

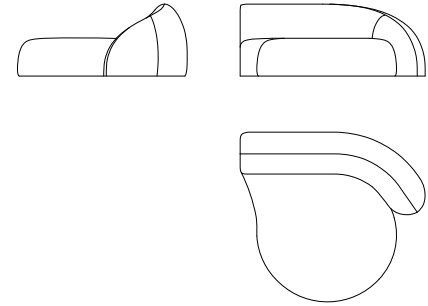

R

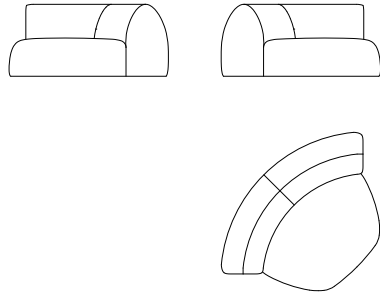

500
L 187 x P 126 x H 71 cm

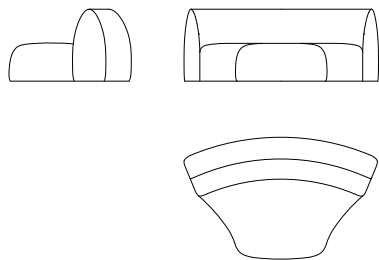

510
L 185 x P 119 x H 71 cm